

# Model L681C

**Extruded Aluminum Louver • 6" Deep • 35° Straight Blades • Combination Adjustable • Concealed Mullion**

## STANDARD CONSTRUCTION

**FRAME:** .081" thk. (nominal) extruded aluminum, 6063-T52/T6 alloy.

**BLADES:** Stationary blades are .081" thk. (nominal) extruded aluminum 6063-T52/T6 alloy. Adjustable blades are .125" thk. (nominal) extruded aluminum 6063-T52/T6 alloy. Blades are approximately 4½" on centers.

**LOUVER FACE:** Full width sill with head and blades contained within jambs. Concealed mullion with continuous length stationary blade.

**LINKAGE:** Extruded aluminum, concealed in the channel out of the airstream. The pivots, which rotate in Celcon bearings, are .50" dia. Zinc plated machined steel. The pivot is locked to the 5/16" dia. aluminum linkage rod by a ¼ - 20 set screw with epoxy locking patch.

**BEARINGS:** Celcon bearing material so there will be no metal to metal scraping.

**SHAFTS:** .50" dia. aluminum "Pin-Lock" rod.

**SEALS:** Extruded silicone rubber seals at blade edge. Foam on bottom blade and polycarbonate jamb seals. Standard stainless steel at jambs required on painted louvers.

**SCREEN:** (When indicated, in a removable frame)  
 ½" flattened aluminum, .051" thk.,  
 -or- Insect screen 1/16" aluminum mesh, .011" dia.,  
 -or- ½" sq. mesh intermediate double crimped aluminum wire, .063" dia.

**FINISH:** Mill.

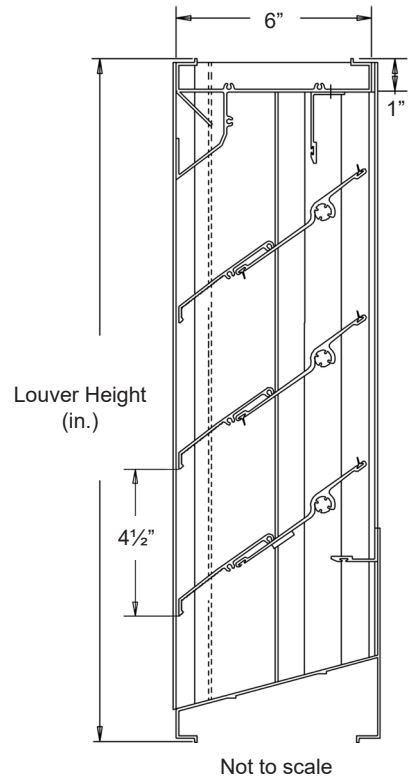

## OPTIONS

Finishes - Enamels, Epoxies, etc.  
 Other screens available.  
 Actuators - Electric, Pneumatic, Manual, etc.

## NOTES

- Nominal deductions will be made to the opening size given.
- Approximate shipping weight is 5.0 lbs./sq.ft.

## LOUVER SIZES

Min Panel	Max Single Panel
12"W x 16"H	96"W x 72"H

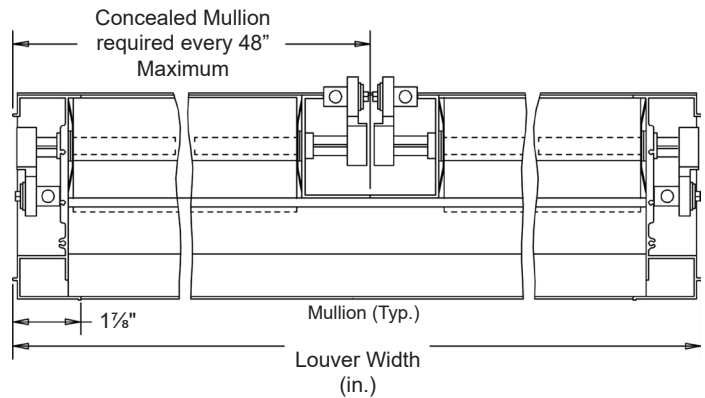
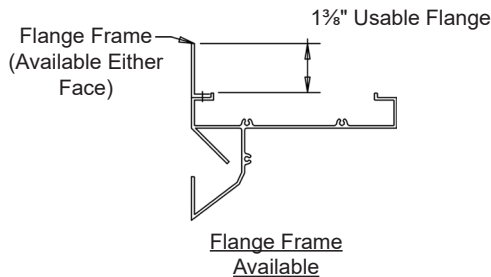

\* Visible Mullion required every 96" maximum.

Item #	Qty	Opening Size		Louver Size		Mullion	Screens		Union Made
		Width	Height	Width	Height		Type	Location	
Arch. / Eng. :						EDR:	ECN:		Job:
Contractor:									
Project:						Date:	DWN:	DWG:	

In the interest of product development, Louvers & Dampers reserves the right to make changes without notice.